

20 X 54MM MINI DOMAL

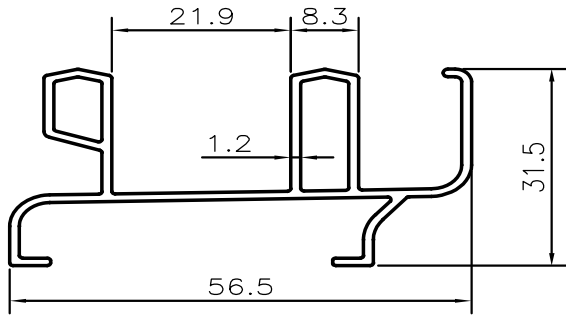

2 TRACK = 16' - 3.000 KGS

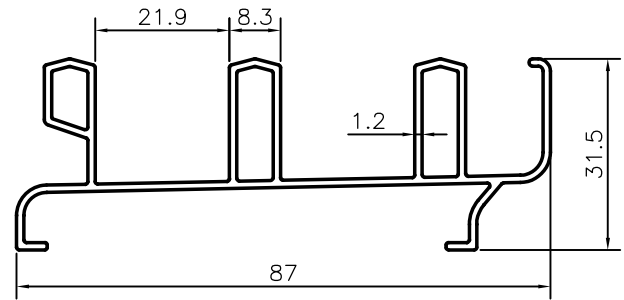

3 TRACK = 16' - 4.300 KGS

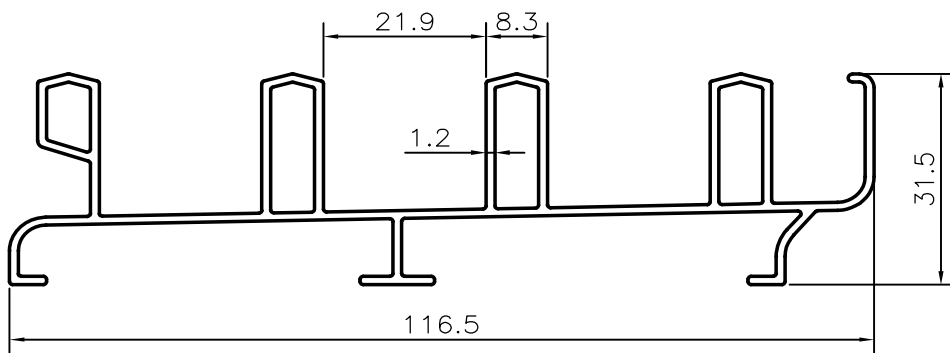

4 TRACK = 16' - 5.900 KGS

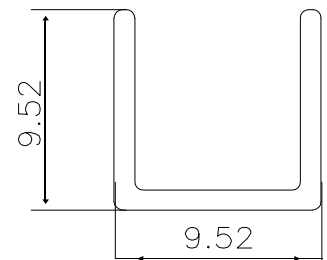

3/8 U CHANNEL = 0.068 Kg/m

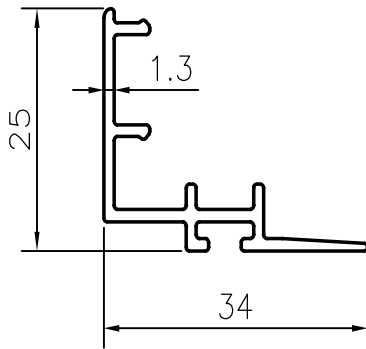

INTER LOCK = 16' - 1.300 KGS

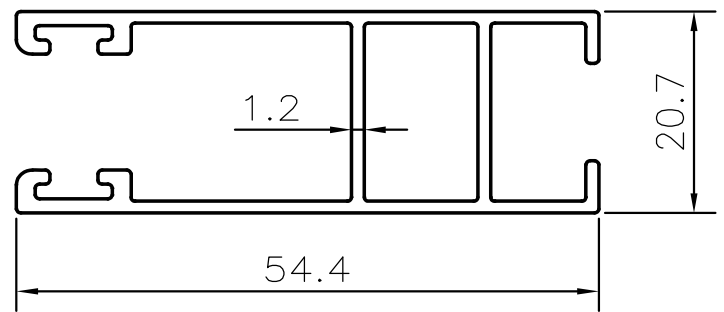

SINGLE GLASS SUTTER = 16' - 2.900 KGS

COMPARISON FOR 6ft x 4ft WINDOW SIZE

18mm (3/4") Series (H) 20 x 54mm Series MINI DOMAL

BENEFITS OF 20 X 54 SERIES

Item	Length	Weight
I.L.	16 F	3.100
BTB	12 F	2.300
HDLE	8 F	1.300
3T TOP	14.5 F	4.480
3T BTM	6 F	2.150
	TOTAL	13.330

Item	Length	Weight
I.L.	16 F	1.300
SHUTTER	36 F	6.450
TRACK	20 F	5.25
	TOTAL	13.00

- Very easy to clean between two track lines.
- No visibility of screws on Window Frames.
- Designed for easy use and taking better load.

NEW 27 X 65MM SERIES (LIGHT)

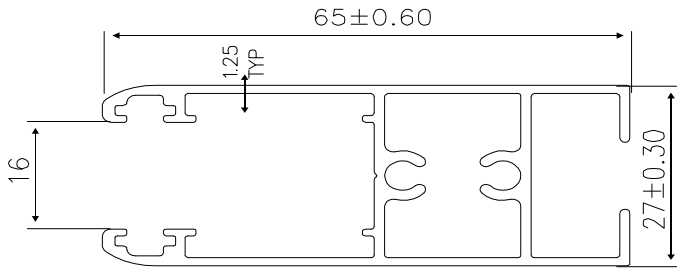

SCREW SHUTTER = 16' - 4.300 KGS

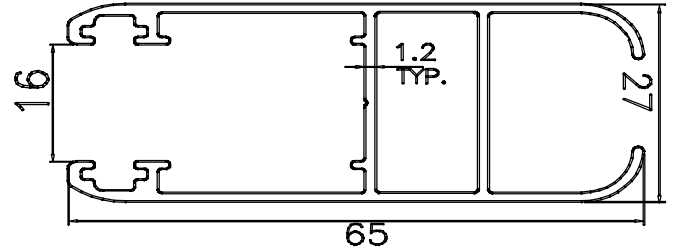

SINGLE GLASS SHUTTER = 16' - 3.500 KGS

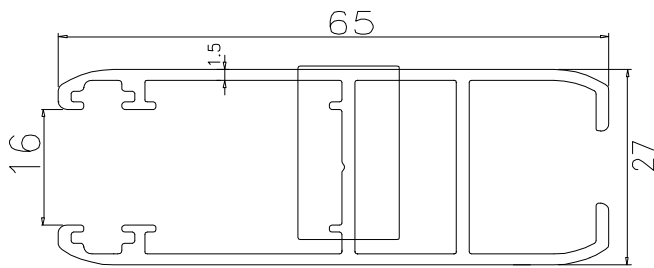

SINGLE GLASS SHUTTER HEAVY = 16' - 4.200 KGS

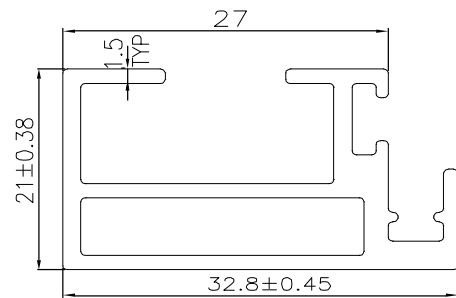

SLIM INTERLOCK = 16' - 2.750 KGS

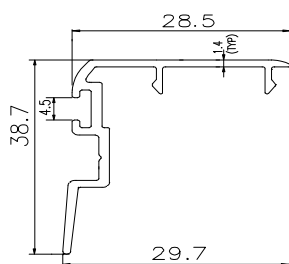

INTER LOCK = 16' - 1.500 KGS

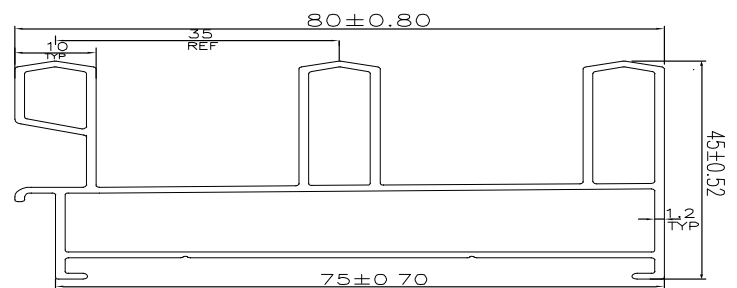

NEW STYLE 3 TRACK = 16' - 6.000 KGS

35 x 75MM SERIES (SINGLE LEG)

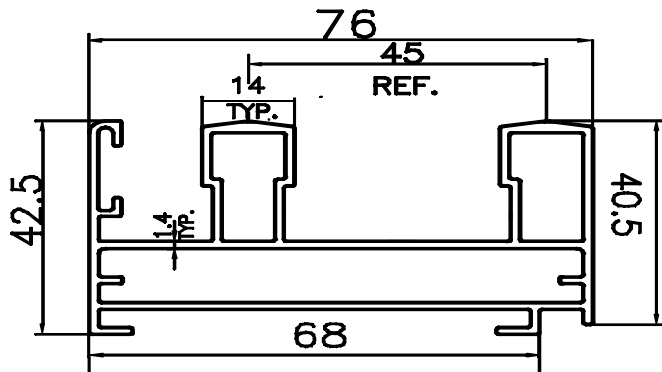

2 TRACK = 16' - 7.200 KGS

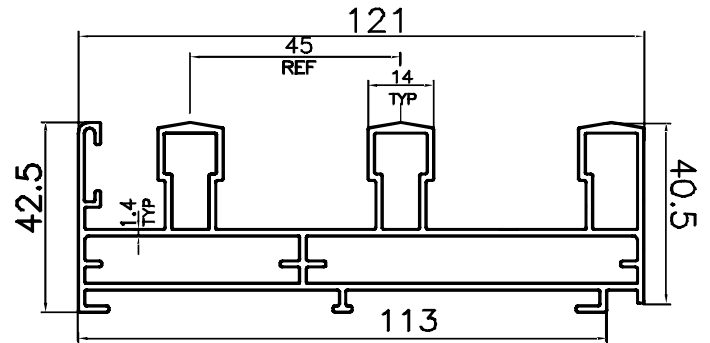

3 TRACK = 16' - 10.000 KGS

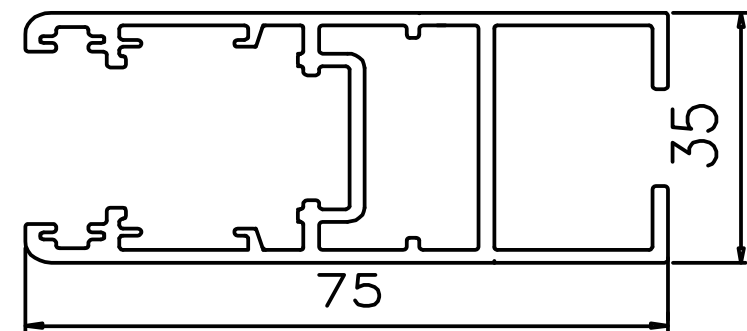

SINGLE GLASS SHUTTER = 16' - 7.700 KGS

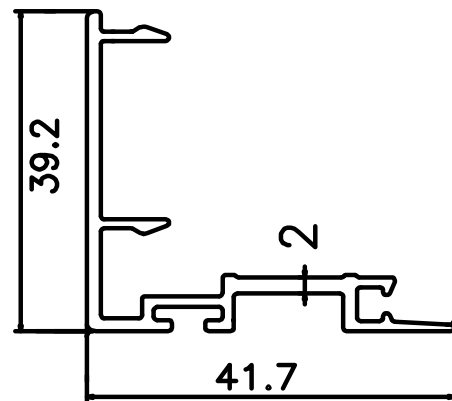

INTER LOCK = 16' - 2.200 KGS

40MM OPENABLE SERIES

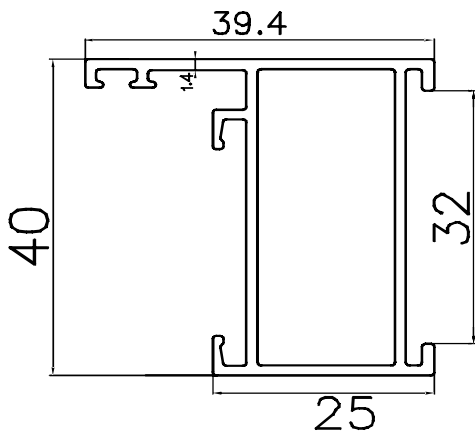

FRAME = 16' - 2.650 KGS

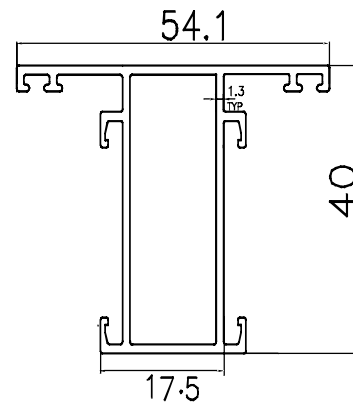

SHUTTER / MULLION = 16' - 3.300 KGS

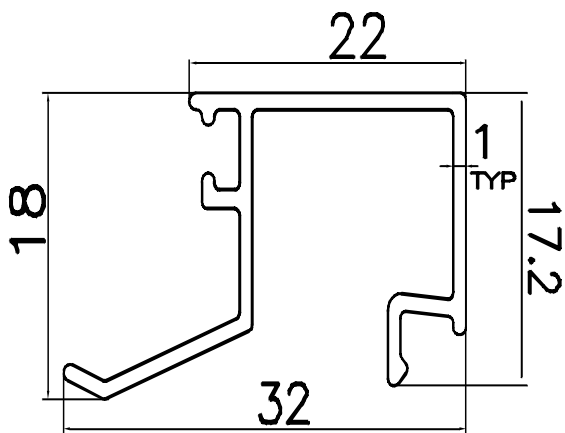

SINGLE GLASS CLIP = 16' - 1.050 KGS

52MM OPENABLE SERIES

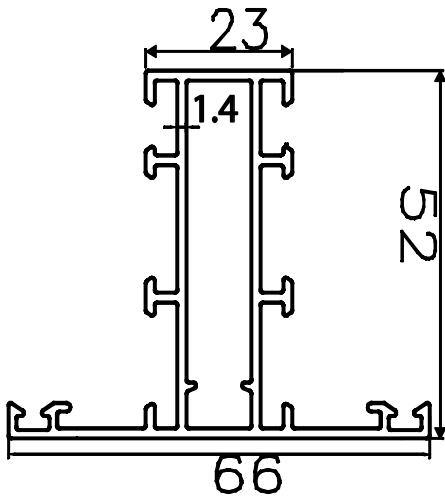

MULLION = 16' - 4.900 KGS

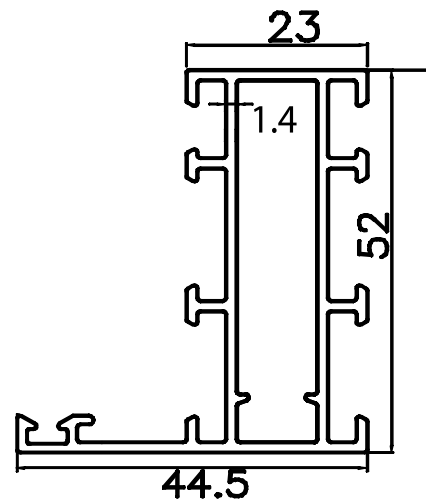

FRAME = 16' - 4.300 KGS

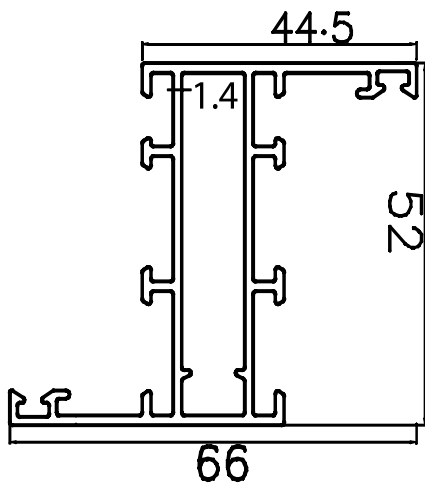

SHUTTER = 16' - 4.750 KGS

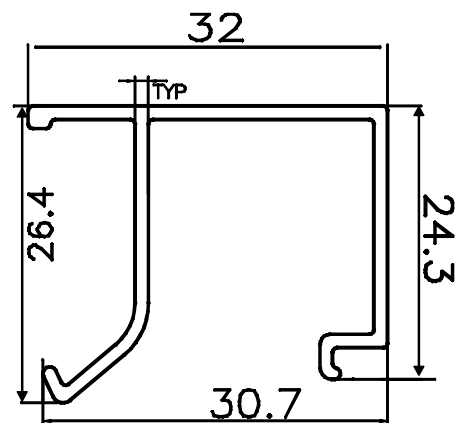

SINGLE GLASS CLIP = 16' - 1.500 KGS